



- This inspection can be carried out by a Department of Transport and Main Roads (TMR) officer for all motorhomes or a Queensland Police Service Officer or a HVRAS Authorised Person for motorhomes over 4.5 tonne only.
- This inspection sheet must be used in conjunction with *Vehicle Details Inspection Sheet (form F3529)* or *Change of Vehicle Particulars (form F3524)*.
- A HVRAS Authorised Person cannot inspect an imported motorhome/campervan prior to first registration in Australia.
- This inspection is for a motorhome/campervan with GVM over 4.5 tonne only. For motorhomes/campervans with a GVM of 4.5 tonne or less a modification certificate with code LH11 is required.
- Do not use this form for a motorhome with a designated load carrying space as it must be registered as a truck or bus.

1. Vehicle details

Make/model

VIN/Chassis/Engine number

2. Is the vehicle imported?

Yes No **Go to Question 3**

Was the trailer previously registered in Australia?

Yes Previous plate number

Go to Question 3

No Vehicle must be presented at a TMR customer service centre for inspection and a copy of the import approval for the vehicle provided.

3. Requirements of a motorhome/campervan

Is the residential quarters permanently fixed to the vehicle? (If 'no' the vehicle does not qualify as a motorhome. Inspect using the correct form for the vehicle when the residential quarters are detached).

Yes No

Is there rigidly fixed sleeping berths?

Yes No

Is there rigidly fixed cooking facilities?

Yes No

Is there a rigidly fixed table? (may be removable)

Yes No

Is there travel seating for all sleeping berths?

Yes No

Are there rigidly fixed storage facilities?

Yes No

Is there an approved fire extinguisher in the living quarters?

Yes No

Is there at least one outward opening or sliding door on the left hand side or rear of the living quarters?

Yes No

The vehicle does not have a designated load carrying area.

Yes No

If the answer is No to any of these questions, this vehicle does not comply. The vehicle must comply with these standards for such registration*. For more information on **vehicles over 4.5 tonne**, contact the National Heavy Vehicle Regulator (NHVR) Vehicle Standards Team on 1300 696 487 or email vehiclestandards@nhvr.gov.au prior to attending a TMR customer service centre to register the vehicle. For more information on **vehicles up to 4.5 tonne**, contact the TMR Vehicle Standards Team at vehiclestandards@tmr.qld.gov.au or 13 23 80.

***Must be assessed using the appropriate inspection sheet for body type.**

4. Measurements

- Vehicles to be measured are all vehicles over 4.5 tonne GVM.
- Using the diagram as a guide, provide the following dimensions in metres correct to two decimal places (e.g. 12.54, 2.42).
- Write the number of tyres per axle in the wheel spaces.
- Letters in circles, for example (R), indicate distances that are able to be calculated using formulas provided.
- If the motorhome/campervan is fitted with a retractable axle, all measurements are to be taken with the retractable axle in contact with the ground and in the lifted position. Use a separate inspection sheet for each configuration.

Motorhome/Campervan with single axles

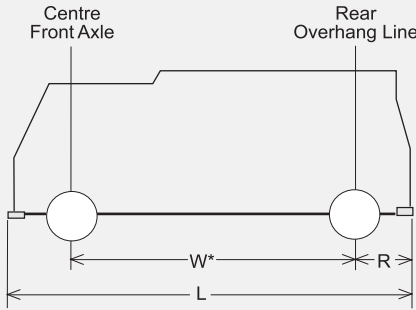

Motorhome/Campervan with axle group/s

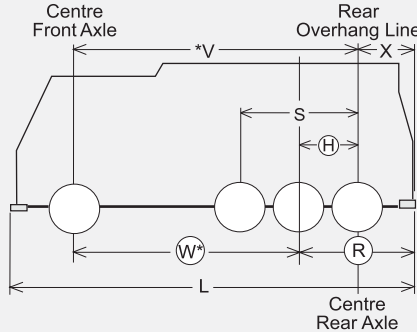

Width	.
Height	.
L	.

For Motorhome/Campervan with a single rear axle.

W	.	*
R	.	

For Motorhome/Campervan with a rear axle group (W) and (R) measurements must be calculated.

V	.
S	.
X	.
(W) = (V - (H)) =	.
(R) = (X + (H)) =	.

* This measurement is the Extreme Axle Distance (EAD) for registration purposes.

5. Rear Overhang Line (for motorhome/campervan with rear axle groups)

Tick (✓) the relevant axle group, then calculate for '(H)' using the formula given.

Rear Axle Group	<input type="checkbox"/> Axle groups with the same number of tyres per axle	<input type="checkbox"/> F (2) (4) R	<input type="checkbox"/> F (4) (2) R
Calculation of '(H)'	$(H) = \frac{S}{2} =$	$(H) = \frac{S}{3} =$	$(H) = \frac{S \times 2}{3} =$

6. Regulation limits

1. Is the width of the vehicle 2.50 metres or less?
2. Is the height of the vehicle 4.30 metres or less?
3. Is 'L' 12.50 metres or less?
4. Is 'R' 3.70 metres or less?
5. Is 'R' equal to or less than 60% of 'W' (i.e. 'W' x 0.6 = _____) ?

- Yes No
- Yes No
- Yes No
- Yes No
- Yes No

If the answer is No to any of these questions, this vehicle does not comply with regulation limits. For more information on **vehicles over 4.5 tonne**, contact the NHVR Vehicle Standards Team on 1300 696 487 or email vehiclestandards@nhvr.gov.au prior to attending a TMR customer service centre to register the vehicle. For more information on **vehicles up to 4.5 tonne**, contact the TMR Vehicle Standards Team at vehiclestandards@tmr.qld.gov.au or 13 23 80.

7. Axle group

1. If the vehicle has a Twin Steer Front Axle Group is the axle group spacing between 1.00 metre and 2.00 metres?
2. If the vehicle has a Tandem Axle Group is 'S' between 1.00 metre and 2.00 metres?
3. If the vehicle has a Rear Tri Axle Group is 'S' between 2.00 metres and 3.20 metres?
4. Is the rear axle group fitted with load sharing suspension?
5. Is the front axle group fitted with load sharing suspension?

- Yes No
- Yes No
- Yes No
- Yes No
- Yes No

If the answer is No to any of these questions, this vehicle does not comply with axle group requirements. For more information on **vehicles over 4.5 tonne**, contact the NHVR Vehicle Standards Team on 1300 696 487 or email vehiclestandards@nhvr.gov.au prior to attending a TMR customer service centre to register the vehicle. For more information on **vehicles up to 4.5 tonne**, contact the TMR Vehicle Standards Team at vehiclestandards@tmr.qld.gov.au or 13 23 80.

8. GVM/GCM details

Front Axle Rating [] kg	Tyre type		Size []	Ply rating []	Load rating []
	Conventional <input type="checkbox"/>	Radial <input type="checkbox"/>			

Rear Axle Rating [] kg	Tyre type		Size []	Ply rating []	Load rating []
	Conventional <input type="checkbox"/>	Radial <input type="checkbox"/>			

GVM [] kg	GCM [] kg
---------------	---------------

GVM/GCM details from: (tick one box)

Identification/Compliance Plate Vehicle/Manufacturer's Plate Modification Plate

Other Please state []

9. Declaration

Inspection was carried out by (tick one box) (Please affix Office/Business stamp)

TMR officer Queensland Police Service Officer HVRAS Authorised Person

I have inspected the vehicle indicated on this form and certify the information contained in this form is complete, true and correct and has been taken from the vehicle itself.

Full name (please print) []	Customer Reference Number []
---------------------------------	----------------------------------

Signature
[]

Date
[]

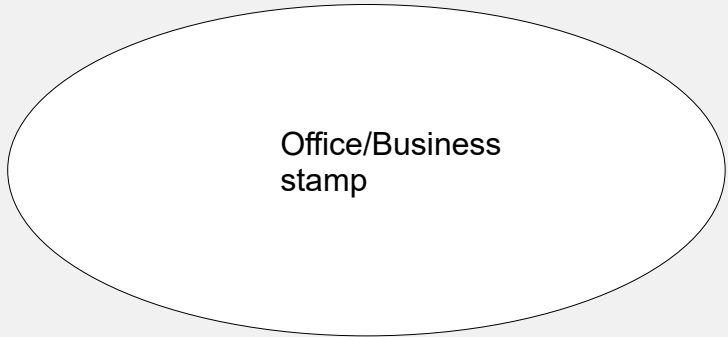

Privacy statement: TMR collects the personal information in the above declaration to support that the inspection has been carried out on the said vehicle. This information may be released by TMR or its agents/contractors to parties such as the NHVR, vehicle insurers, statutory/insolvency entities, lawyers, persons involved in vehicle accidents/incidents and to or through interstate registering authorities. This information will be held by TMR and your personal information will not be disclosed to a third party without your consent, unless authorised or required to do so by law.