



National Written-Off Vehicle Notification Industry

Transport Operations (Road Use Management) Act 1995 (TORUM)

This form must be completed and sent to the jurisdiction where the vehicle is, or was, last registered before disposing of the vehicle. If the vehicle has never been registered, the form should be sent to the jurisdiction in which the vehicle was based at the time of the incident. You should check with the applicable registration authority about the vehicle age limits and coverage.

* Mandatory information

Vehicle details Vehicle type*: (Please tick) Motor vehicle Caravan Trailer Motorcycle

Make* Model*

Registration number State or Territory Engine number

Vehicle Identification Number (17 characters) Date of manufacture / / Incident date / /

Label number 1 (SA, TAS) Label number 2 (TAS) Approval number (SA)

Notifier details

Note: High volume or regular notifiers should consult their registration authority about alternative arrangements for reporting of name and other notifier details.

Family name* Given name/s* Customer Reference Number (CRN)*

Company/Business name* ABN/ACN* *CRN can be your driver licence number, Adult Proof of Age (APA) Card number or Department of Transport and Main Roads (TMR) CRN.

Address*

Postcode

Telephone number* Mobile number Email address

Type of notifier*: (please tick)

Insurer Auction house Dealer Auto dismantler Assessor Owner

Other Please specify Client/customer/notifier reference number (NSW, QLD, SA) Insurance claim number

Write-off type*: (please tick) Repairable Statutory Salvage retained by notifier* Yes No Odometer

Write-off date / /

First incident type Incident type code:

Damage location	1	2	3	4	5	6	7	8	9	10	11	12	13	14	15	16	17	18	19	20	21
Damage severity																					
Damage location	22	23	24	25	26	27	28	29	30	31	32	33	34	35	36	37	38	39	40	41	
Damage severity																					

Second incident type Incident type code:

Damage location	1	2	3	4	5	6	7	8	9	10	11	12	13	14	15	16	17	18	19	20	21
Damage severity																					
Damage location	22	23	24	25	26	27	28	29	30	31	32	33	34	35	36	37	38	39	40	41	
Damage severity																					

Statutory declaration

I declare that the information given on this form is true and correct and acknowledge the privacy statement shown on page 2 of this form.

If notifying on behalf of a company (full name)

Signature

Date

 / /

Damage details* (up to two incident types may be recorded)

A full description of the national damage assessment criteria and how to apply them is set out in the publication *Damage Assessment Criteria for the Classification of Statutory Write-offs* (2011) published by the National Motor Vehicle Theft Reduction Council and Austroads. A PDF version of the publication can be downloaded for free of charge from carsafe.com.au or austrads.com.au

- Incident type code:** Select the 'incident type' that has resulted in the damage from one of the six kinds listed below and enter the code letter next to the First incident type. If a second 'incident type' is involved, enter the application code letter next to the Second incident type.
- Damage location:** Refer to the diagrams and list below and match an appropriate damage severity code to each location where the vehicle is damaged. Enter the 'damage severity codes' against the numbered 'damage locations' in the First incident type table located on page 1. Only use the second table if a Second incident type has also caused damage.

Damage coding

Incident type code

D Dismantled F Fire H Hail I Impact M Malicious/vandalism/stripped W Water (salt or fresh)

Damage severity code

A Heavy panel	E Unrepairable	I Minor stripping	M Water (fresh)
B Light panel	F Major mechanical damage	J Major vandalism	N Burnt/blistered
C Heavy structural	G Minor mechanical damage	K Minor vandalism	O Smoke and heat
D Light structural	H Major stripping	L Water (salt)	P Minor smoke

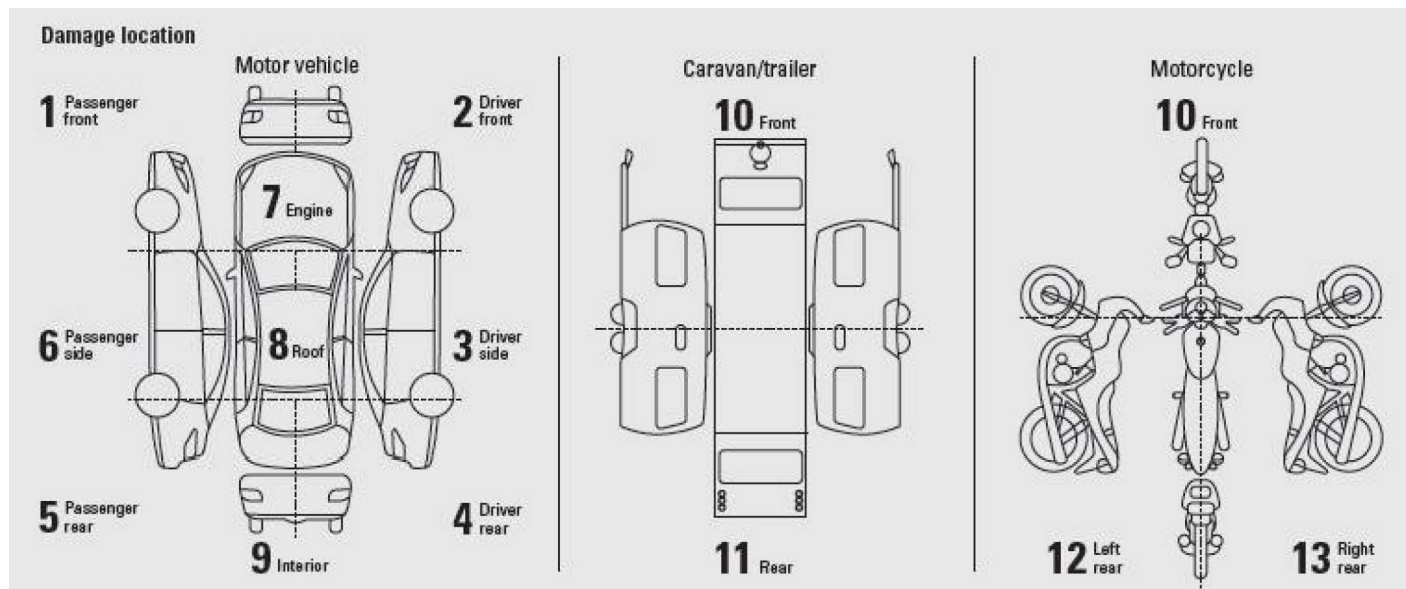

14 Whole vehicle	21 Chassis/structural rails (driver)	28 D pillar passenger	35 Suspension (driver front)
15 Floor plan (passenger front)	22 A pillar passenger	29 D pillar driver	36 Suspension (passenger rear)
16 Fire wall	23 A pillar driver	30 Engine block (cracked, fractured)	37 Suspension (driver rear)
17 Chassis/structural rails (passenger)	24 B pillar passenger	31 Transmission case	38 Airbag front
18 Floor pan (driver rear)	25 B pillar driver	32 Differential case	39 Airbag side
19 Floor pan (driver front)	26 C pillar passenger	33 Axle housing	40 Airbag curtain
20 Floor plan (passenger rear)	27 C pillar driver	34 Suspension (passenger front)	41 Seat belt pre-tensioner

Registration authority contact

Vehicle Identification Unit
 Customer Service Operations
 Department of Transport and Main Roads
 GPO Box 5232
 BRISBANE QLD 4001
 Phone: 1300 308 630
 Email: viunit@tmr.qld.gov.au

Privacy Statement: TMR collects information on this form under the TORUM to manage TMR's vehicle register. This information may be released by TMR to parties such as written-off vehicle inspectors, Police and to or through interstate registering authorities. This information is accessible by authorised departmental officers and your personal information will not be disclosed to other third parties without your consent unless authorised or required to do so by law.