

Written-Off Vehicle Correction Advice

Transport Operation (Road Use Management) Act 1995



Queensland
Government

This form must be used by a Written-off Vehicle notifier when applying to the Department of Transport and Main Roads to have corrections made to a written-off vehicle notification made by the notifier.

Previously notified details

Vehicle Identification Number (VIN)

Notifier's details

WOVR notifier reference number

Business/Company name

Contact number

Correction request (tick appropriate box/es)

Vehicle details – complete Section 1, 4 and 6

Written-off details – complete Section 3, 4 and 6

Damage details – complete Section 4, 5 and 6

Write-off type – complete Section 2, 4 and 6

Section 1 – Vehicle details

Vehicle Identification Number (VIN)

Make, Model & Body Shape (e.g. Ford Falcon Station Wagon)

Engine number (if available)

Registration / Plate number (if available)

Vehicle type: (Please tick)

Motor vehicle

Motorcycle

Trailer

Caravan

Section 2 – Write-off type (tick one box only)

Repairable write-off

A vehicle that has been damaged to the extent that its salvage value plus cost of repairing the vehicle for use on the road is more than its market value.

Statutory write-off

A vehicle that is dismantled or is too badly damaged to be repaired to a standard that is safe for road use, therefore it is suitable only for use as parts or scrap. The vehicle's VIN will be identified on the written-off vehicle register as a statutory write-off, and the vehicle will not be eligible for registration.

Section 3 – Written-off details

Incident date

Odometer reading

kms

Written-off date

Section 4 – Reason for change

Has the vehicle been disposed of? Yes No

Continued over page...

Privacy statement— The Department of Transport and Main Roads (the department) collects information on this form under the *Transport Operations (Road Use Management) Act 1995* to manage the department's vehicle register. This information may be released by the department to parties such as Written-off vehicle inspectors, police and to or through interstate registering authorities. This information is accessible by authorised departmental officers and your personal information will not be disclosed to other third parties without your consent unless authorised or required to do so by law.

Section 5 – Damage coding

Incident type code

D Dismantled **F** Fire **H** Hail **I** Impact **M** Malicious/vandalism/stripped **W** Water (salt or fresh)

Damage severity code

A Heavy panel	E Unrepairable	I Minor stripping	M Water (fresh)
B Light panel	F Major mechanical damage	J Major vandalism	N Burnt/blistered
C Heavy structural	G Minor mechanical damage	K Minor vandalism	O Smoke and heat
D Light structural	H Major stripping	L Water (salt)	P Minor smoke

1st Incident type

Incident type code:

Damage location	1	2	3	4	5	6	7	8	9	10	11	12	13	14	15	16	17	18	19	20	21	
Damage severity																						
Damage location	22	23	24	25	26	27	28	29	30	31	32	33	34	35	36	37	38	39	40	41		
Damage severity																						

2nd Incident type

Incident type code:

Damage location	1	2	3	4	5	6	7	8	9	10	11	12	13	14	15	16	17	18	19	20	21	
Damage severity																						
Damage location	22	23	24	25	26	27	28	29	30	31	32	33	34	35	36	37	38	39	40	41		
Damage severity																						

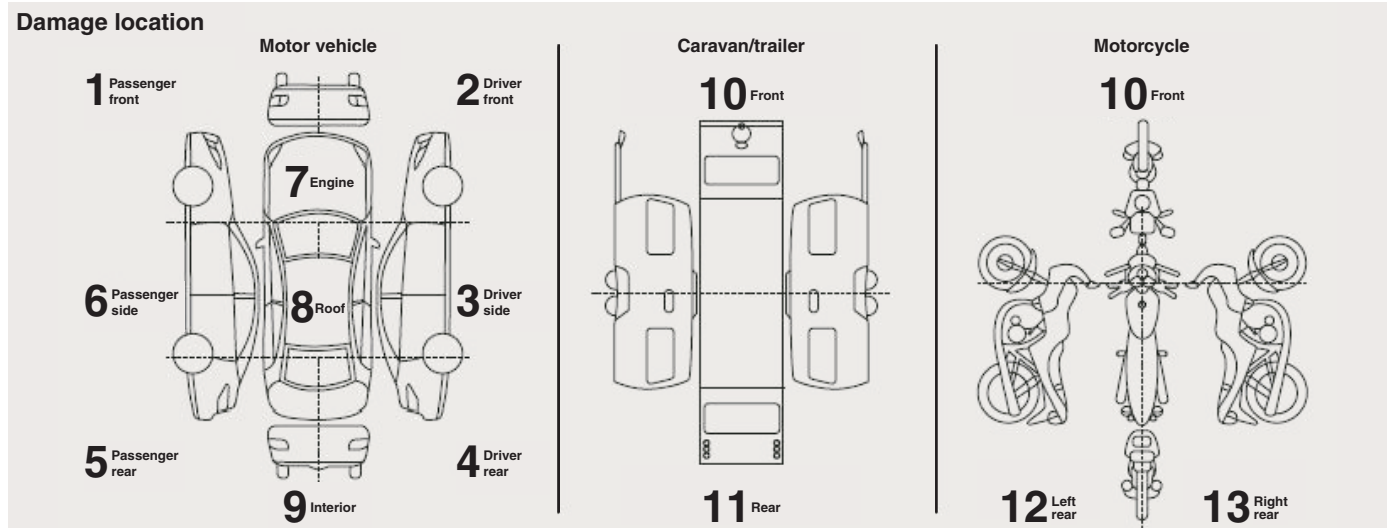

14 Whole vehicle	21 Chassis/structural rails (driver)	28 D pillar passenger	35 Suspension (driver front)
15 Floor pan (passenger front)	22 A pillar passenger	29 D pillar driver	36 Suspension (passenger rear)
16 Fire wall	23 A pillar driver	30 Engine block (cracked, fractured)	37 Suspension (driver rear)
17 Chassis/structural rails (passenger)	24 B pillar passenger	31 Transmission case	38 Airbag front
18 Floor Pan (driver rear)	25 B pillar driver	32 Differential case	39 Airbag side
19 Floor pan (driver front)	26 C pillar passenger	33 Axle housing	40 Airbag curtain
20 Floor pan (passenger rear)	27 C pillar driver	34 Suspension (passenger front)	41 Seat belt pre-tensioner

Section 6 – Notifier’s declaration

Business/Company name WOVr notifier reference number

Contact number Fax number Email address

I declare that the information given on this form is true and correct. I understand if at any time the information is found to be false or misleading, I could be subject to a penalty.

Contact name (please PRINT) Signature Date